

# 85 SX 2006







**SPARE PARTS MANUAL: ENGINE**

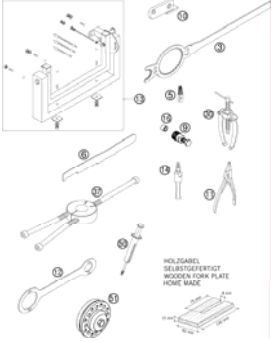

ART.NO.: 3CM080403EN

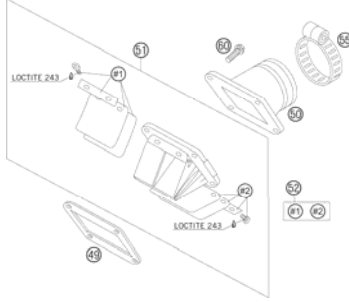
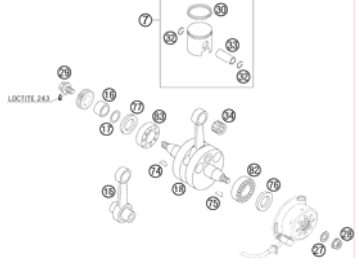
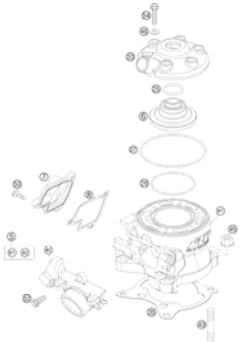
ENGLISH

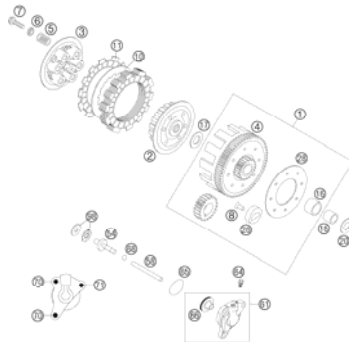

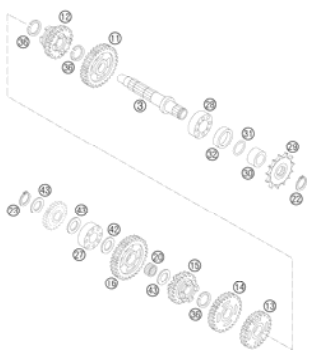
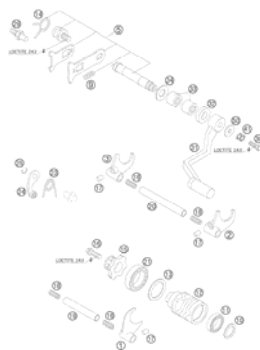
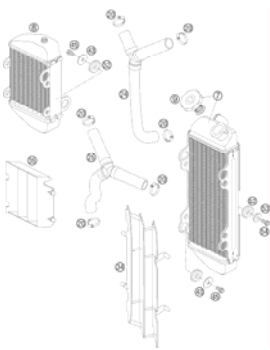

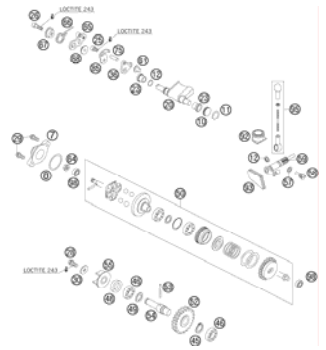
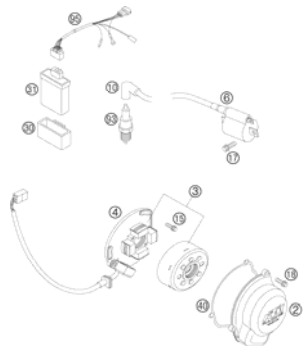
<p><b>SPECIAL TOOLS</b></p>  <p>HOLZGABEL SELBSTGEFERTIGT WOODEN FORM PLATE HOME MADE</p> <p><b>3</b></p>	<p><b>ENGINE CASE</b></p>  <p><b>4</b></p>	<p><b>REED VALVE CASE</b></p>  <p>LOCTITE 243</p> <p><b>5</b></p>	<p><b>CRANKSHAFT, PISTON</b></p>  <p>LOCTITE 243</p> <p><b>6</b></p>
<p><b>CYLINDER</b></p>  <p><b>7</b></p>	<p><b>CARBURETOR</b></p> <p>ACHTUNG !!! Vor dem Einbau des Vergasers, Beddringung kontrollieren! CAUTION !!! Before mounting the carburetor, check the jetting.</p>  <p><b>8</b></p>	<p><b>CLUTCH</b></p>  <p><b>10</b></p>	<p><b>KICKSTARTER</b></p>  <p>LOCTITE 243</p> <p><b>11</b></p>
<p><b>TRANSMISSION I</b></p>  <p>LOCTITE 243</p> <p><b>12</b></p>	<p><b>TRANSMISSION II</b></p>  <p><b>13</b></p>	<p><b>SHIFTING MECHANISM</b></p>  <p>LOCTITE 243</p> <p><b>14</b></p>	<p><b>COOLING SYSTEM</b></p>  <p><b>15</b></p>

<p><b>EXHAUST CONTROL</b></p>  <p><b>16</b></p>	<p><b>IGNITION SYSTEM</b></p>  <p><b>18</b></p>		
	<div style="display: flex; align-items: center;">  <p>All information contained is without obligation. KTM-Sportmotorcycle AG particularly reserves the right to modify any equipment, technical specifications, prices, colors, shapes, materials, services, service work, constructions, equipment and the like so as to adapt them to local conditions or to cancel any of the above items, all without previous announcement and without giving reasons. KTM may stop manufacturing certain models without previous notice. KTM shall not be held liable for any deviations of availability and/or ability to deliver, illustrations, descriptions, printing and/or other errors. The illustrated models partly contain extra equipment, which is not applied to standard models.          © 2004 by KTM-SPORTMOTORCYCLE AG, Mattighofen AUSTRIA; All rights reserved; Reprint, also in extracts, with written allowance of KTM-SPORTMOTORCYCLE AG, Mattighofen only.</p> </div>		

# SPECIAL TOOLS

85 SX 2006

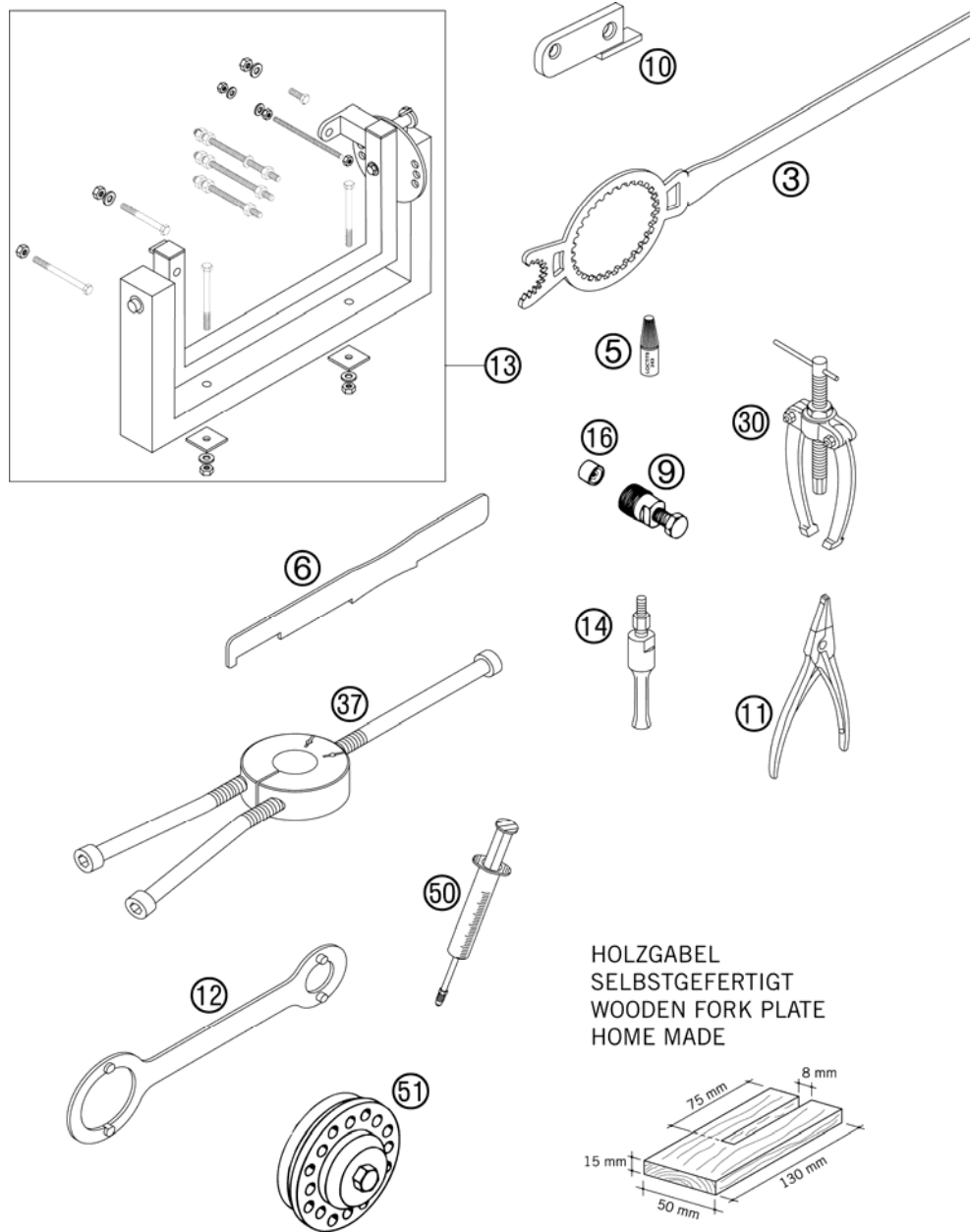

HOLZGABEL  
SELBSTGEFERTIGT  
WOODEN FORK PLATE  
HOME MADE

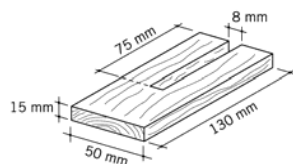

FIG	PART NUMBER	DESCRIPTION	QTY
3	47029003000	CLUTCH HOLDER 85 SX 2003	1
5	6899785	LOCTITE 243 BLUE 6CCM	1
6	47029006000	ADJUSTING PLATE 85 SX 2003	1
9	54629009044	MAGNETIC PULLER M 27X1 KOKUSAN	1
10*	47029002000	ENGINE HOLDER RIGHT 85	1
11	51012011000	SPECIAL CIRCLIP PLIER	1
12	54629012100	HOLD. SPANNER ROTOR 2K-1/2/3/4	1
13*	56012001044	UNIVERSAL MOUNTING RACK CPL.	1
14	15112018200	INTERN.BEAR.PULLER 5-7 MM	1
16	51012016000	PROTECTION CAP CRANKSHAFT M12	1
30	15112017000	BUSHING EXTRACTOR	1
37	58429037031	MOUNTING TOOL INNER RING NJ205	1
50	50329050000	VENT INJEKTION HYDR. CLUTCH	1
51	47029027000	RIVETTING TOOL FOR CLUTCH	1

064702900 / C064702900

\* NEW PART

X AS REQUIRED

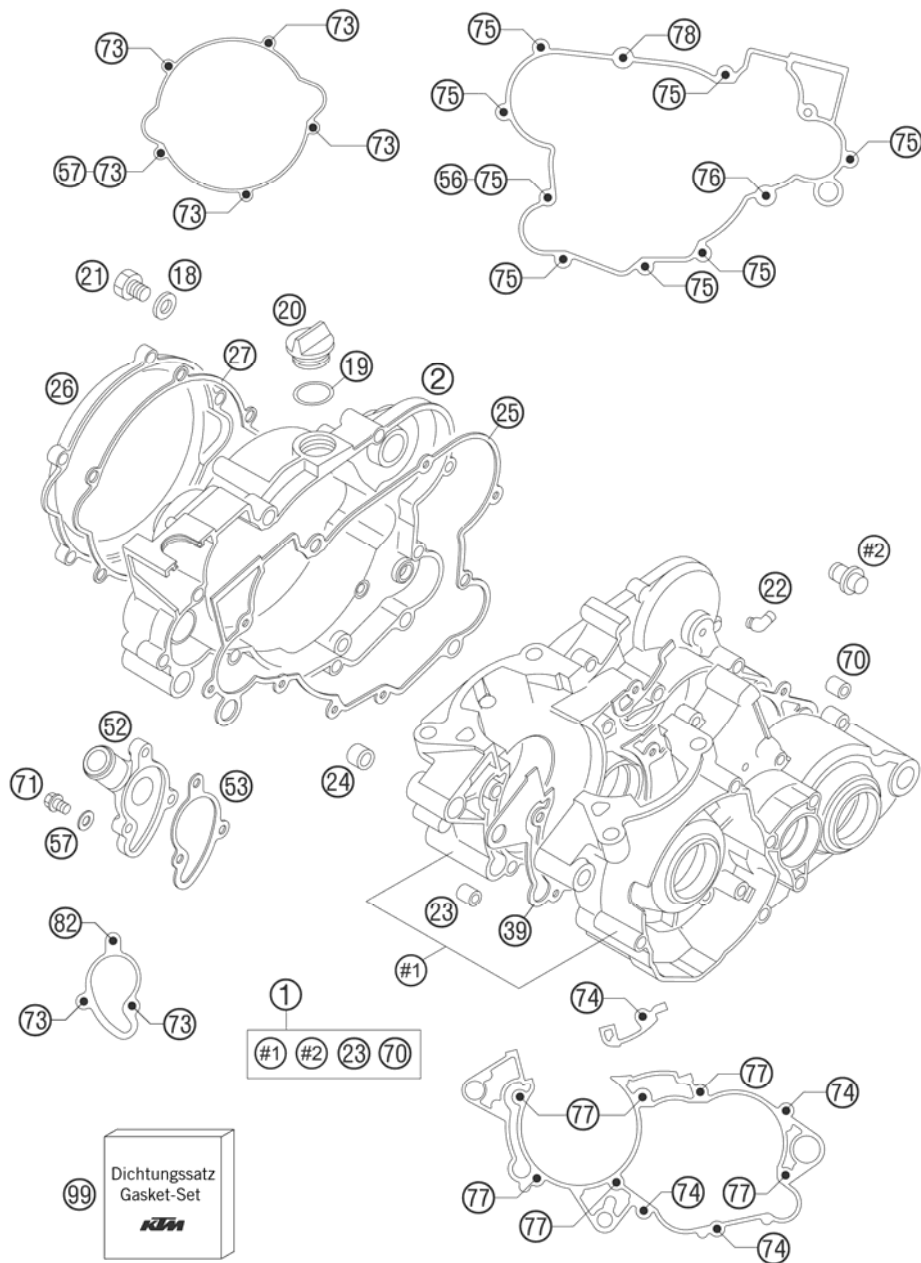

FIG	PART NUMBER	DESCRIPTION	QTY
1	4703000044	ENGINE CASE CPL. 85 SX 2003	1
2*	47030001100	CLUTCH COVER CPL. 85 SX 06	1
18	0603101420	COPPER GASKET 10,2X14X2 MM 01	1
19	0770160030	O-RING 16,00X3,00 NBR 70	1
20	58030020000	PLUG M 24X3	1
21	46030021100	OIL DRAIN PLUG M10 WS=13	1
22	45130022000	ANGLE PIECE 50CCM LC 2001	1
23	47030023100	DOWEL 13X13	1
24	45130023000	DOWEL 7X9X10	1
25	47030025000	INNER CLUTCH COVER GASKET	1
26*	47030101100	OUTER CLUTCH OVER 85 SX 06	1
27*	47030027100	GASKET FOR OUTER CLUTCH COVER	1
39	47030039000	GASKET F. ENGINE CASE 85 SX 03	1
52	47035052000	WATER PUMP COVER 85 SX 2003	1
53	47035053000	GASKET FOR WATER PUMP COVER 03	1
56	47003071000	SPRINGHOLDER	1
57	0603061001	CU-SEAL RING DIN7603-6X10X1	2
70	47030023000	DOWEL 14,5X19	1
71	0015060103	HH COLLAR SCREW M 6X10 WS=8	1
73	0015060203	HH COLLAR SCREW M 6X20 WS=8	7
74	0015060253	HH COLLAR SCREW M 6X25 WS=8	4
75	0015060303	HH COLLAR SCREW M 6X30 WS=8	8
76	0015060353	HH COLLAR SCREW M 6X35 WS=8	1
77	0015060403	HH COLLAR SCREW M 6X40 WS=8	6
78	0015060453	HH COLLAR SCREW M 6X45 WS=8	1
82	0015060653	HH COLLAR SCREW M 6X65 WS=8	1
99	47030099100	GASKET SET CPL. 85/105SX 04	1

05470300 / C064703000

\* NEW PART

X AS REQUIRED

# REED VALVE CASE

85 SX 2006

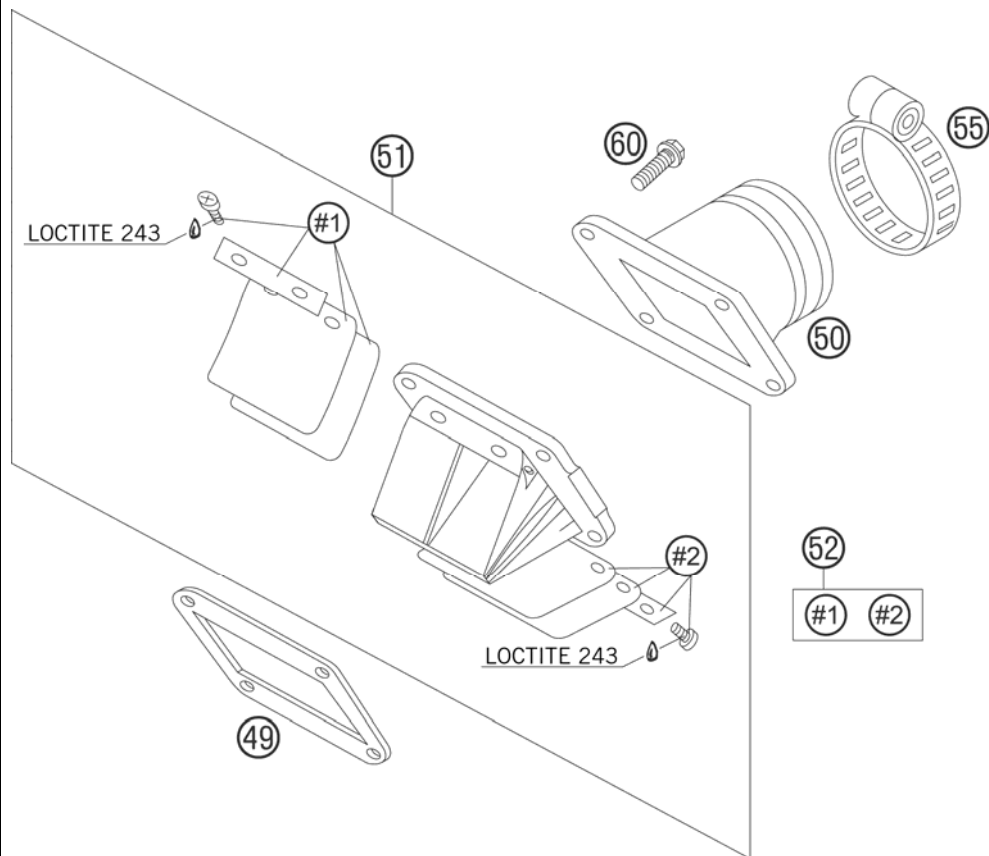

FIG	PART NUMBER	DESCRIPTION	QTY
49	47030049000	GASKET FOR INTAKE FLANGE 85 SX	1
50	47030050000	INTAKE FLANGE 85 SX 2003	1
51	47030051044	REED VALVE ASSY CPL.85 SX 2003	1
52	47030052004	REED VALVE CPL. 85 SX 2003	2
55	51230061000	CLAMP 40/12 GEMI	1
60	0015060203	HH COLLAR SCREW M 6X20 WS=8	4

05470301 / C064703001

\* NEW PART

X AS REQUIRED

# CRANKSHAFT, PISTON

85 SX 2006

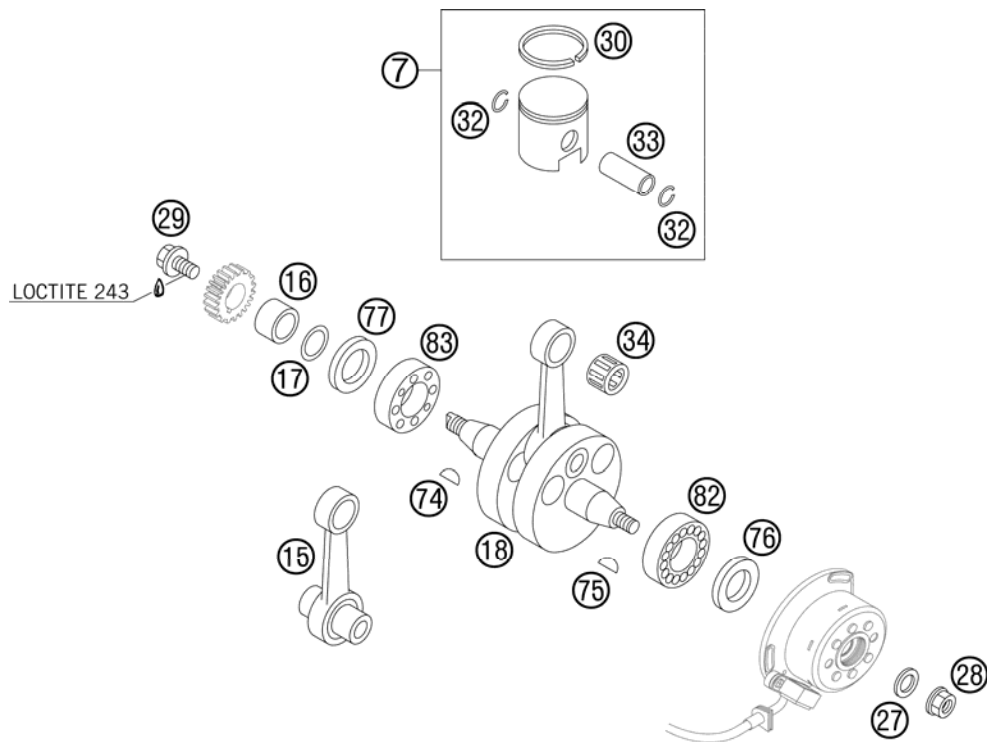

FIG	PART NUMBER	DESCRIPTION	QTY
7*	47030007100 I	PISTON CPL. 47MM SIZE 1 2005	1
7*	47030007100 II	PISTON CPL. 47MM SIZE 2 2005	1
15	47030015000	CON. ROD. REP. KIT 85 SX 2003	1
16	47030016000	SPACER SLEEVE 85 SX 2003	1
17	0770020180	O-RING 18,77X1,78 NBR 70	1
18	47030018000	CRANKSHAFT CPL. 85 SX 2003	1
27	50230029012	LOCKING RING VSK 12	1
28	49030021000	COLLAR NUT M12X1 R/S	1
29	47032019000	HH SCREW W. COLLAR M10X1,25X20	1
30	47030030000	PISTON RING 85 SX 2003	1
32	47030074000	WIRE LOCK RING 85 SX 2003	2
33	47030033000	PISTON PIN 85 SX 2003	1
34	47030034000	NEEDLE BEARING KBK 14X18X17 03	1
74	0888040050	WOODRUFF KEY DIN6888 4X5X13	1
75	0888030050	WOODRUFF KEY DIN6888-3X5X13	1
76	47030076100	SEAL SHAFT RING 20X35X6 BTSL	1
77	0760304260	SHAFT SEAL RING 30X42X6	1
82	47030082000	CYL.ROLLER BEAR. NJ205ET2XCS42	1
83	47030083000	BALL BEARING 22X52X15	1

064703002 / C064703002

\* NEW PART

X AS REQUIRED



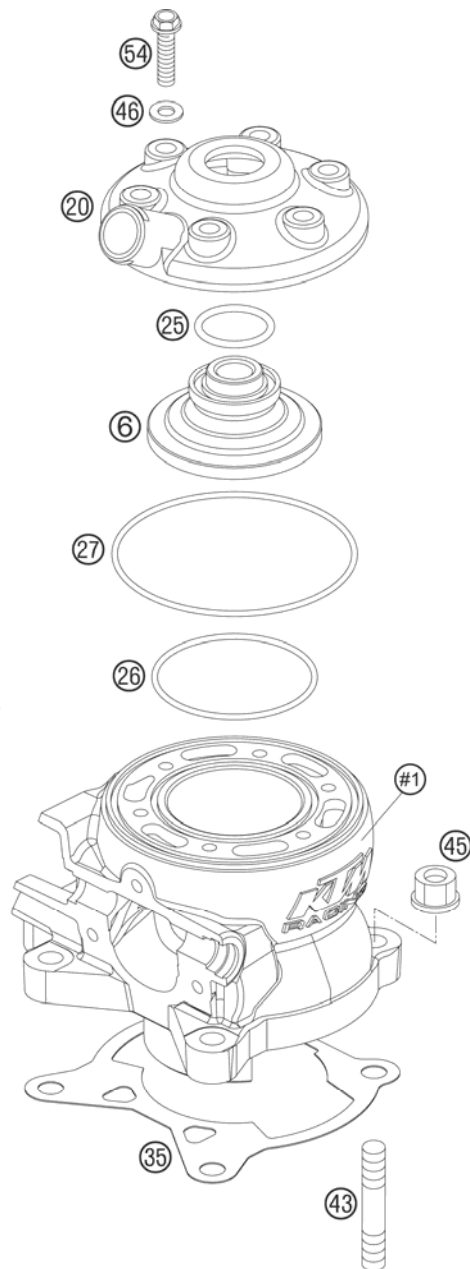

FIG	PART NUMBER	DESCRIPTION	QTY
5	47030005044	CYLINDER W. FLANGE 85 SX 2003	1
6	47030106000	CYLINDER HEAD INSERT 85 SX 03	1
7	47037007000	CONTROL COVER 85 SX 2003	1
8	47037008000	GASKET FOR CONTROL COVER 2003	1
20	47030006000	CYLINDER HEAD 85 SX 2003	1
25	0770220025	O-RING 22,00X2,5 VITON 75SH	1
26	0770540020	O-RING 54X2 VITON	1
27	0770820020	O-RING 82X2 SILICONE	1
35	47030035000	CYLINDER BASE GASKET 0,50MM	x
35	47030035020	CYLINDER BASE GASKET 0,20MM	x
35	47030035030	CYLINDER BASE GASKET 0,30MM	x
43	0835080240	STUD DIN 0835-M 8X24	4
45	46030045000	COLLAR NUT M8 WS=10	4
46	0603061001	CU-SEAL RING DIN7603-6X10X1	6
50	0015050123	HH COLLAR SCREW M 5X12 WS=8	3
52	0015060163	HH COLLAR SCREW M 6X16 WS=8	3
54	47030079000	CYL.HEAD BOLT 85 SX 05	6

05470303 / C064703003

\* NEW PART

X AS REQUIRED

▲ **ACHTUNG !!!**  
 Vor dem Einbau des Vergasers, Bedüsung kontrollieren.  
**CAUTION !!!**  
 Before mounting the carburetor, check the jetting.

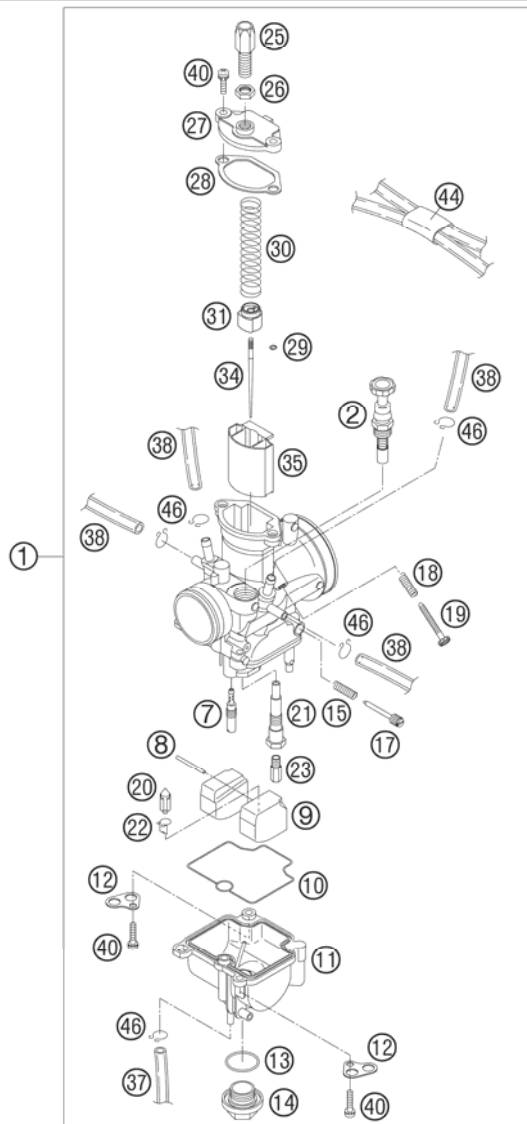

FIG	PART NUMBER	DESCRIPTION	QTY
1	47031001000	CARBURETOR KEIHIN PWK 28 2003	1
2	54631245000	STARTER PISTON CPL.	1
7	54531607038	IDLE JET 38 KEIHIN	x
7	54531607040	IDLE JET 40 KEIHIN	x
7	54531607042	IDLE JET 42 KEIHIN	x
7	54531607045	IDLE JET 45 KEIHIN	1
7	54531607048	IDLE JET 48 KEIHIN	x
7	54531607050	IDLE JET 50 KEIHIN	x
8	57331008000	ARM PIN FLOAT	1
9	47031009000	FLOAT CPL. PWK28 03	1
10	47031010000	FLOAT CHAMBER GASKET	1
11	47031011000	FLOAT CHAMBER PWK28 03	1
12	54531612100	RETAINING PLATE FOR BLEEDER	2
13	0770180230	O-RING 18,00X2,30 NBR 70	1
14	57331014000	% HOLDING BOLT	1
15	54531615000	SPRING FOR ADJUSTMENT SCREW	1
17	54531617000	ADJUSTMENT SCREW	1
18	54631118000	SPRING	1
19	54631219100	ADJUSTMENT SCREW M 5	1
20	47031020000	FLOAT NEEDLE CPL.	1
21	47031021000	NEEDLE JET	1
22	47031022000	CLIP FOR FLOAT VALVE	1
23	54531623115	MAIN JET 115 KEIHIN	x
23	54531623118	MAIN JET 118 KEIHIN	1
23	54531623120	MAIN JET 120 KEIHIN	x
23	54531623122	MAIN JET 122 KEIHIN	x
23	54531623125	MAIN JET 125 KEIHIN	x
25	54531625000	ADJUSTMENT SCREW M 6X0,75	1
26	52031126000	HEXAGON NUT M 6X0,75 DIN0439	1
27	47031027000	CARBURETOR COVER PWK28 03	1
28	47031028000	CARBURETOR COVER GASKET PWK28	1
29	54531629000	CLIP FOR JET NEEDLE	1
30	47031030000	THROTTLE VALVE SPRING	1
31	47031031000	SPRING CAP	1
34	47031034000	JET NEEDLE N5HG KEIHIN	1
34	47031034100	JET NEEDLE N5HF KEIHIN	x

05470310 / C064703100

\* NEW PART

X AS REQUIRED

▲ **ACHTUNG !!!**  
 Vor dem Einbau des Vergasers, Bedüsung kontrollieren.  
**CAUTION !!!**  
 Before mounting the carburetor, check the jetting.

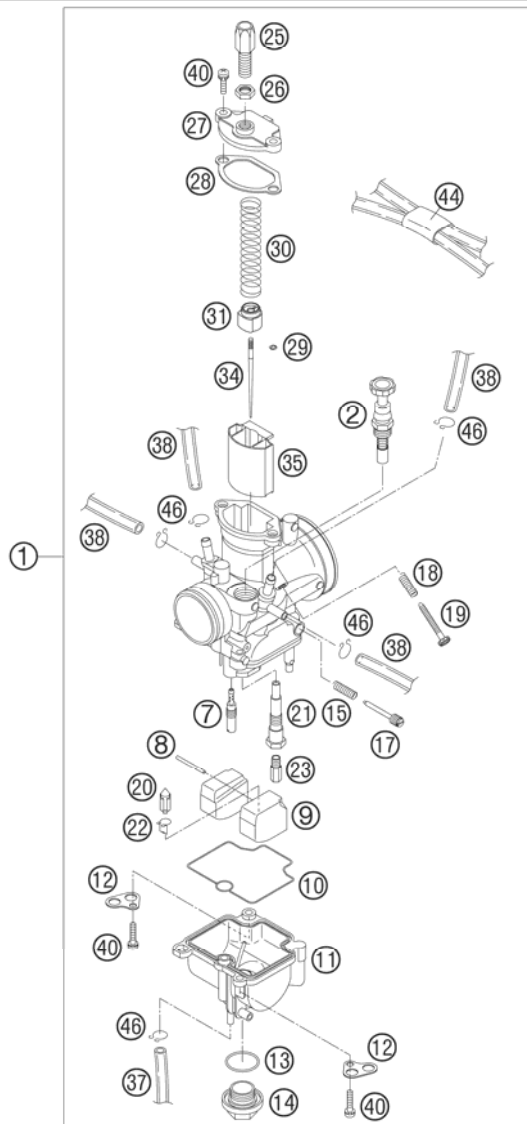

FIG	PART NUMBER	DESCRIPTION	QTY
34	47031034200	JET NEEDLE N5HH KEIHIN	x
35	47031035000	THROTTLE VALVE 3,5	1
37	52031137001	PVC-HOSE 3X5MM	x
38	31007007101	PVC-HOSE 4X6MM	2
40	0016040163	HH COLLAR SCREW M 4X16 WS=6	4
44	47031084000	PLASTIC-CLIP	1
46	54531696000	CLAMP 6 MM	5

05470310 / C064703100

\* NEW PART

X AS REQUIRED

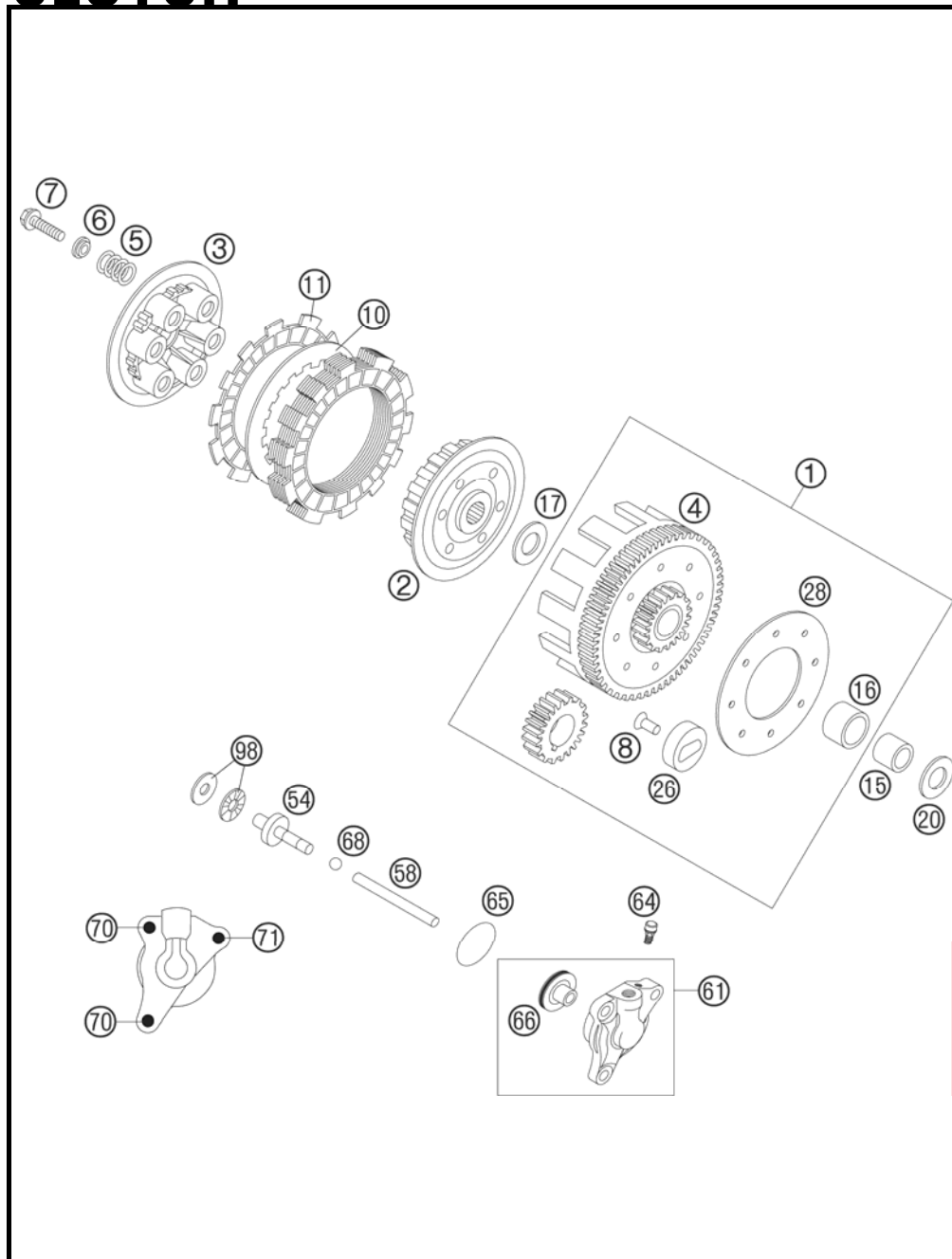

FIG	PART NUMBER	DESCRIPTION	QTY
1	47032001044	OUTER CLUTCH HUB CPL. 85 SX 03	1
2	47032002000	INNER CLUTCH HUB 85 SX 2003	1
3	47032003000	PRESSURE CAP 85 SX 2003	1
4	47032001000	OUT. CLUTCH HUB LOOSE 85 SX 03	1
5	47032005000	CLUTCH SPRING 85 SX 2003	5
6	47032006000	SPRING RETAIN. 5,1X10,2X15X2,5	5
7	0015050203	HH COLLAR SCREW M 5X20 WS=8	5
8	47032008000	RIVET DIN0661 5X14	6
10	47032010000	STEEL DISC 85 SX 03	6
11	47032011000	LINING DISC 85 SX 2003	7
15	47032015000	BUSHING 20X25X20,5	1
16	47032016000	INNER RING 25X28X20	1
17	47032017000	SUPPORT WASHER 18,5X35X1,5 03	1
20	47032020000	STOP DISC 20X32X2	1
26	47032026000	DAMPING ELEMENT 85 SX 2003	6
28	47032028000	RETAINING PLATE 85 SX 2003	1
54	47032054000	PRESSURE PLATE 85 SX 2003	1
58	47032058000	PUSH ROD 85 SX 2003	1
61	59032061044	OUTPUT CYLINDER CPL. 2003	1
64	54732064000	BLEEDER SCREW WITH CAP	1
65	0770300015	O-RING 30,00X1,50 NBR 70	1
66	59032066000	PISTON WITH O-RING AND BALL 03	1
68	47032068000	BALL D=6MM 85 SX 2003	1
70	0015060163	HH COLLAR SCREW M 6X16 WS=8	2
71	0015060203	HH COLLAR SCREW M 6X20 WS=8	1
98	47032098000	AXIAL NEEDLE BEARING 85 SX 03	1

03470320 / C064703200

\* NEW PART

X AS REQUIRED

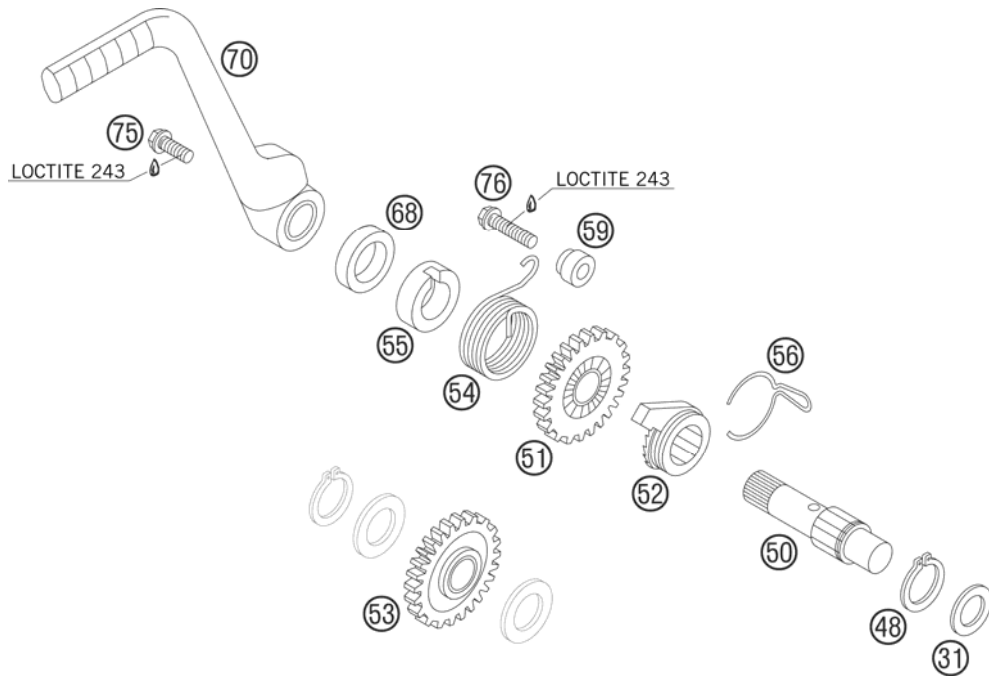

FIG	PART NUMBER	DESCRIPTION	QTY
31	47033040000	STOP DISC 15X25X1	1
48	0471190120	CIRCLIP DIN0471-19X1,2	1
50	47033050000	KICKSTART SHAFT 85 SX 2003	1
51	47033051000	KICKSTART GEAR 85 SX 2003	1
52	47033052000	RATCHET GEAR 85 SX 2003	1
53	47033053000	KICKST. INTERMEDIATE GEAR 2003	1
54	47033054000	KICKSTART SPRING 85 SX 2003	1
55	46033055000	DRIVING HUB	1
56	47033056000	RATCHET GEAR SPRING 85 SX 2003	1
59	47033059000	SPRING SPACER 85 SX 2003	1
68	0760142460	SHAFT SEAL RING 14X24X6 B	1
70	47033070000	KICKSTARTER CPL. 85 SX 2003	1
75	0015060163	HH COLLAR SCREW M 6X16 WS=8	1
76	0015050253	HH COLLAR SCREW M 5X25 WS=8	1

05470330 / C064703300

\* NEW PART

X AS REQUIRED

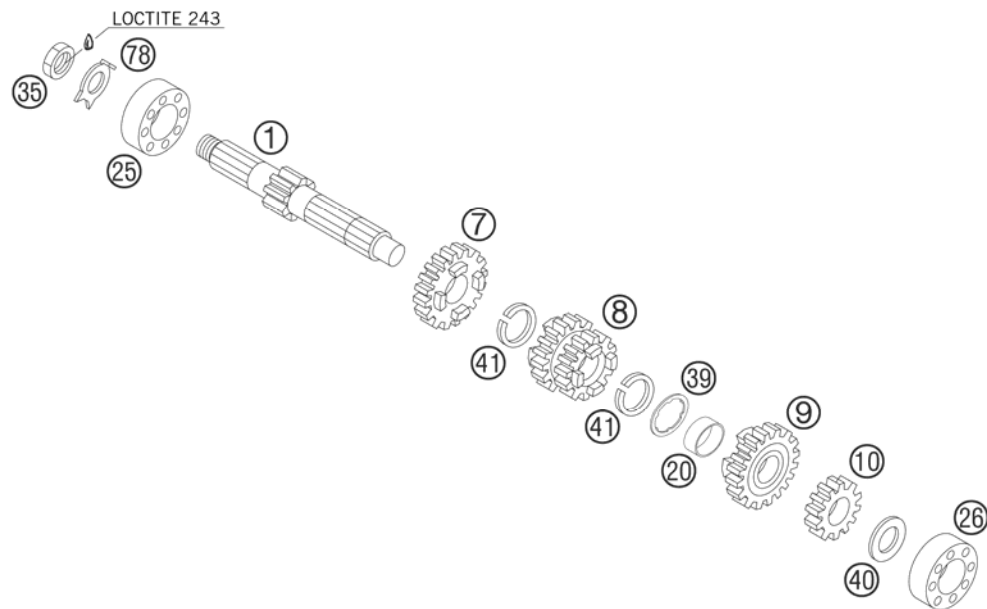

FIG	PART NUMBER	DESCRIPTION	QTY
1	47033001000	MAIN SHAFT 11-T 85 SX 2003	1
7	47033007000	IDLER GEAR 5TH G. 21-T 03	1
8	47033008000	SLID. GEAR 3RD/4TH G. 16/19-T	1
9	47033009100	IDLER GEAR 6TH G. 20-T 05	1
10	47033010000	SOLID GEAR 2ND G. 14-T 03	1
20	47033020000	IDLER GEAR BUSHING 05	1
25	46033028000	GROOVED BALL BEARING 20X42X12	1
26	47033026000	BALL BEARING 16X35X8	1
35	46030029000	HH NUT 14X1,25X7 WS=22	1
39	47033039000	STOP DISK 05	1
40	47033041000	STOP DISC 16X26X1	1
41	47033096000	AXIAL CIRCLIP 19 SW	2
78	46030078000	LOCKING PLATE D=14MM	1

05470331 / C064703301

\* NEW PART

X AS REQUIRED

# TRANSMISSION II

85 SX 2006

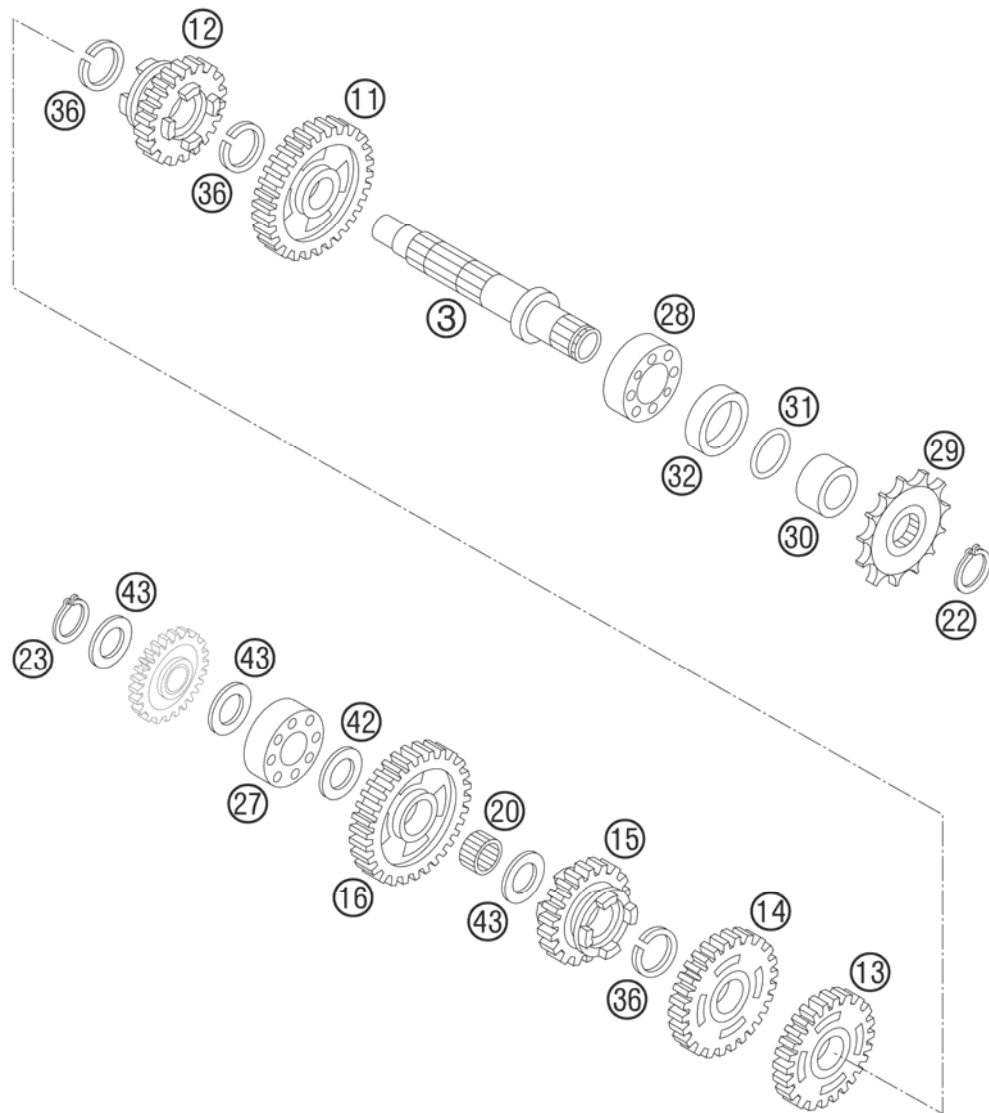

FIG	PART NUMBER	DESCRIPTION	QTY
3	47033003000	COUNTERSHAFT 85 SX 2003	1
11	47033011000	IDLER GEAR 2ND G. 28-T 03	1
12	47033012000	SLIDING GEAR 6TH G. 21-T 03	1
13	47033013000	IDLER GEAR 3ND G. 26-T 03	1
14	47033014000	IDLER GEAR 4TH G. 26-T 03	1
15	47033015000	SLIDING GEAR 5TH G. 25-T 03	1
16	47033016000	IDLER GEAR 1ST G. 29-T 03	1
20	47033099000	NEEDLE BEARING K15X19X10S	1
22	49033091000	CIRCLIP AS20X1,75	1
23	0471150010	CIRCLIP DIN0471-15X1	1
27	0625160026	BALL BEARING 16002	1
28	0625062041	BALL BEARING 6204 JR2 C4	1
29	47033029013	ENGINE SPROCKET 13-T 85 SX 03	x
29	47033029014	ENGINE SPROCKET 14-T 85 SX 03	1
30	47033030000	SPACER FOR SPROCKET	1
31	46033031000	O-RING 18,77X1,78	1
32	0760263560	SHAFT SEAL RING 26X35X6	1
36	0417210120	CIRCLIP SW21	3
42	47033040000	STOP DISC 15X25X1	1
43	47033043000	STOP DISC 15X25X0,5	3

03470332 / C064703302

\* NEW PART

X AS REQUIRED

# SHIFTING MECHANISM

85 SX 2006

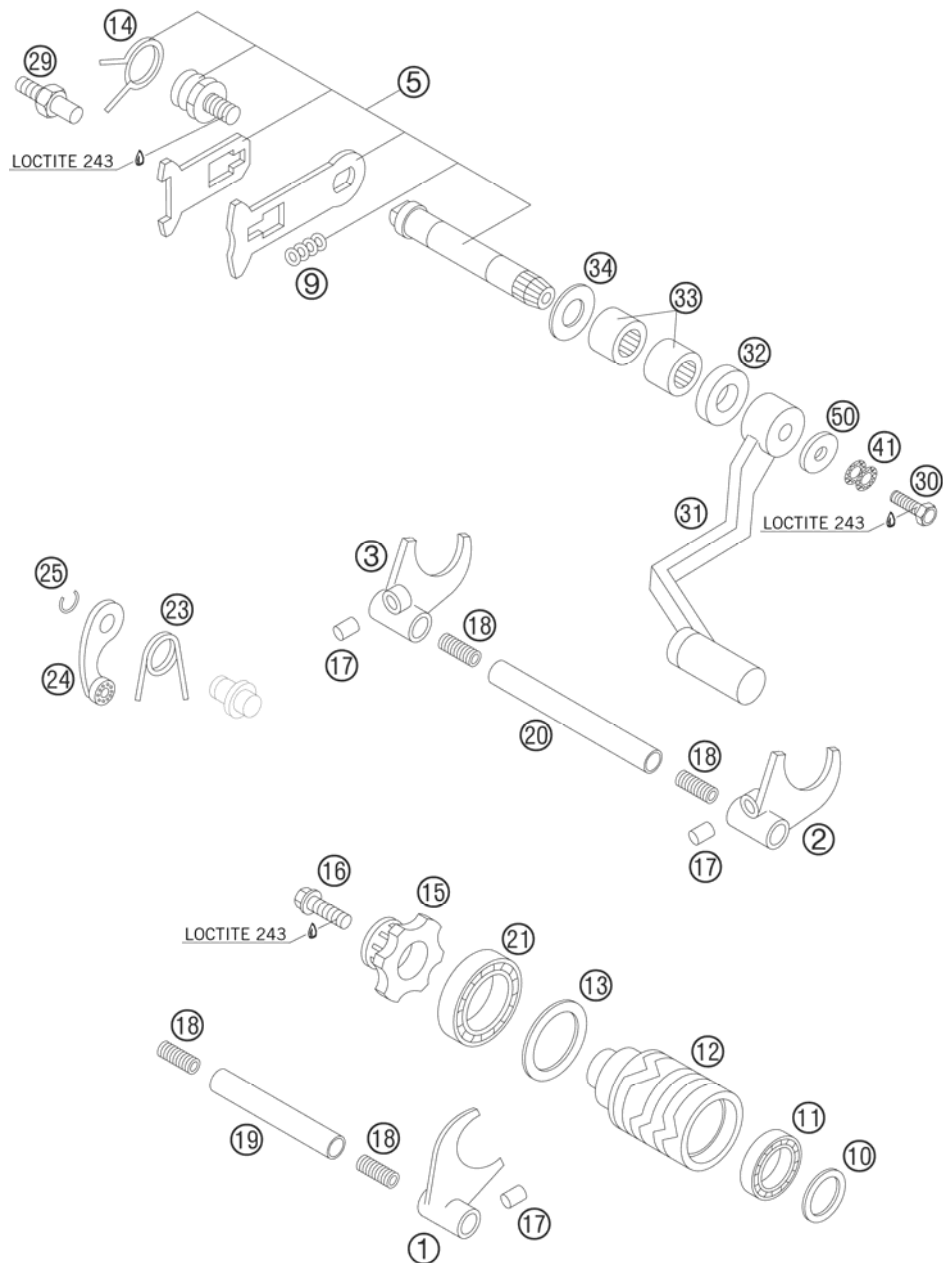

FIG	PART NUMBER	DESCRIPTION	QTY
1	47034001000	SHIFT FORK 5TH/6TH GEAR 2003	1
2	47034002000	SHIFT FORK 2ND/3RD GEAR 2003	1
3	47034003000	SHIFT FORK 1ST/4TH GEAR 2003	1
5	47034005044	SHIFTING SHAFT CPL. 85 SX 2003	1
9	46034009000	PRESSURE SPRING SLIDER PLATE	1
10	47034091000	WASHER 15X20X0,5	1
11	0625069020	BALL BEARING 6902 15X28X7	1
12	47034012000	SHIFT ROLLER 85 SX 2003	1
13	47034092000	WASHER 25X32X0,5	1
14	46034014000	RETURN SPRING	1
15	47034015000	SHIFT LOCATION DRUM 85 SX 2003	1
16	0015060253	HH COLLAR SCREW M 6X25 WS=8	1
17	0402061200	NEEDLE ROLLER DIN5402 NRB 6X12	3
18	46034019052	SPRING SHIFT RAIL 2001	4
19	47034019000	SHIFTING RAIL 85 SX 2003	1
20	46034020100	SHIFT RAIL 2001	1
21	0625618050	BALL BEARING 61805 C3	1
23	46034023100	LOCKING LEVER SPRING 2001	1
24	46034024100	LOCKING LEVER CPL. 65 SX 2002	1
25	0471100010	CIRCLIP DIN0471-10X1	1
29	47034029000	ARRESTER FOR SPRING 2003	1
30	0933060205	HH SCREW DIN933 M6x20 10.9	1
31	47034031000	SHIFT LEVER 85 SX 2003	1
32	0760142460	SHAFT SEAL RING 14X24X6 B	1
33	54632095000	NEEDLE BEAR.HK 1412 14X20X12	2
34	47033043000	STOP DISC 15X25X0,5	1
41	50233041000	PAIR OF WASHERS M 6 NORDLOCK	1
50	50232050001	STEEL WASHER 6,4X17X3	1

05470340 / C064703400

\* NEW PART

X AS REQUIRED



# COOLING SYSTEM

85 SX 2006

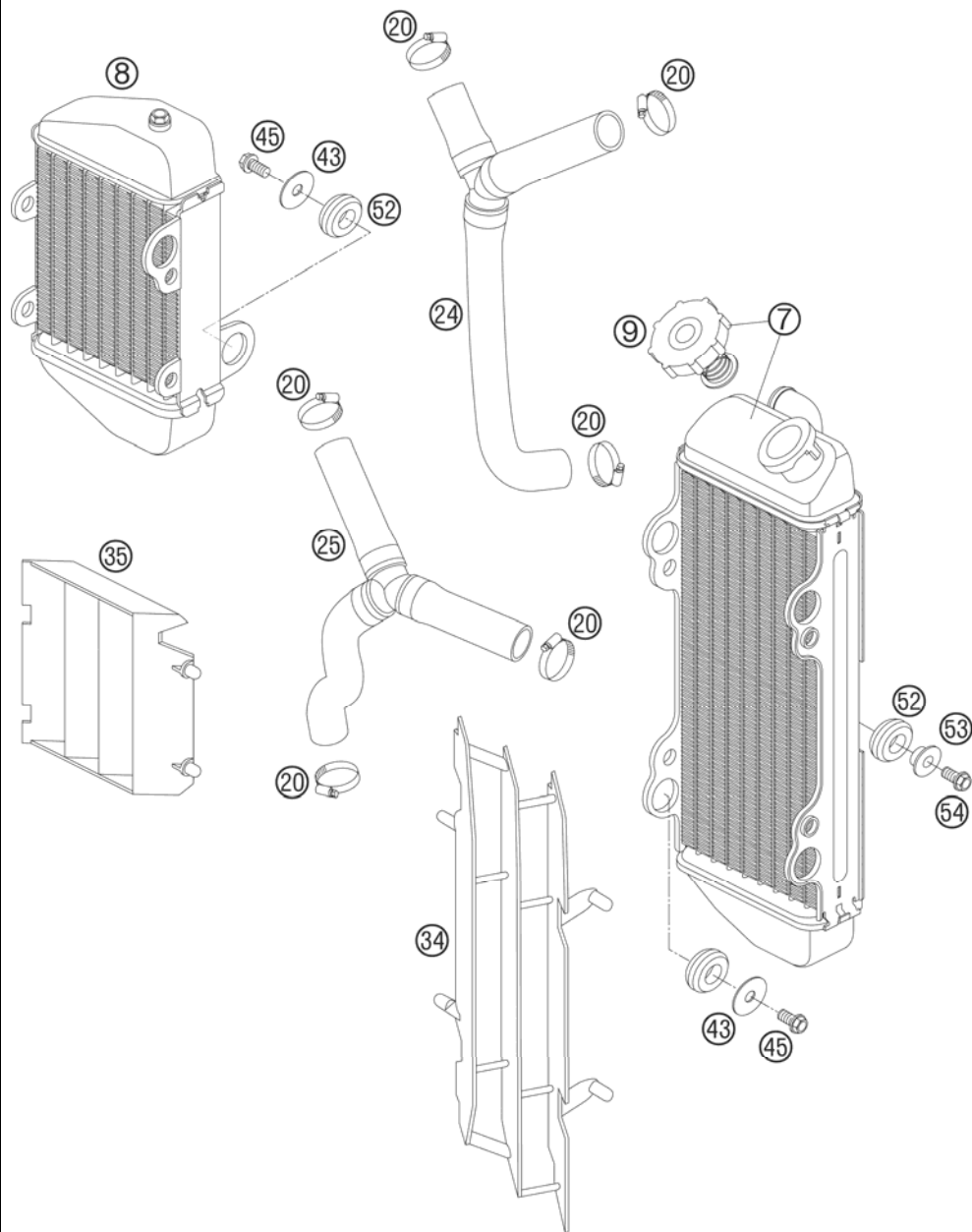

FIG	PART NUMBER	DESCRIPTION	QTY
7	47035007100	RADIATOR L/S 85 SX 2005	1
8	47035008000	RADIATOR R/S 85 SX 2003	1
9	59035009000	RADIAT.CAP 20,3PSI (1,4BAR) 03	1
20	10001020000	HOSE CLAMP GEMI 16-27	6
24	47035024000	RADIATOR HOSE TOP 85 SX 2003	1
25	47035025000	RADIATOR HOSE BOTTOM 85 SX 03	1
34	54635034200	RAD. PROTECT.L/S COLORLESS '95	1
35	47035035000	RADIATOR PROTECT. R/S 85 SX 03	1
43	0021060003	WASHER DIN9021-A 6,4	5
45	0015060123	HH COLLAR SCREW M 6X12 WS=8	5
52	41001052000	RUBBER SLEEVE D=12MM	8
53	50308053000	BUSH FOR SPOILER 6X11X16X7,5	1
54	0015060163	HH COLLAR SCREW M 6X16 WS=8	1

05470350 / C064703500

\* NEW PART

X AS REQUIRED

# EXHAUST CONTROL

85 SX 2006

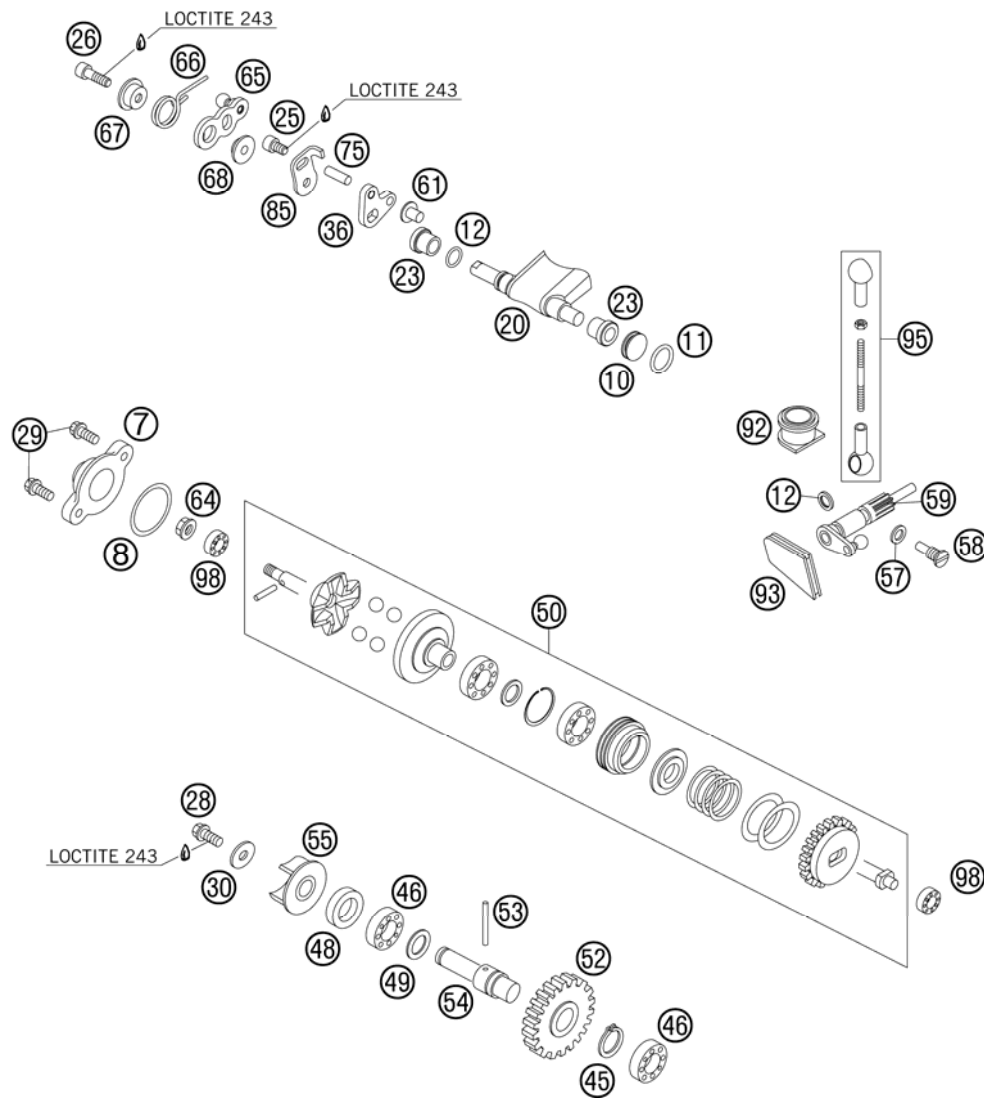

FIG	PART NUMBER	DESCRIPTION	QTY
7	54637070200	CLOSING COVER 2003	1
8	0770020200	O-RING 21,95X1,78 NBR	1
10	47037010000	CLOSING COVER 85 SX 2003	1
11	0770120020	O-RING 12,00X2,00 NBR 70	1
12*	54632090000	SEAL RING DH/GR 12X16X3	1
20	47037020000	CONTROL FLAP 85 SX 03	1
23	47037023000	BEARING SLEEVE 85 SX 2003	2
25	0912050063	AH SCREW DIN 912 M 5X6	1
26	0912050163	AH SCREW DIN0912-M 5X16	1
28	0015050123	HH COLLAR SCREW M 5X12 WS=8	1
29	0015050203	HH COLLAR SCREW M 5X20 WS=8	2
30	0349000050	WASHER DIN7349-5X15X2	1
36	47037036000	DRIVER SHEET 85 SX 2003	1
45	0471100010	CIRCLIP DIN0471-10X1	1
46	0625006087	GROOVED BALL BEAR. 608 2RS C3	2
48	0760082472	SHAFT SEAL RING 8X24X7 A DUO	1
49	54334015000	WASHER 10X14X0,5 STEEL	1
50	47037050044	CENTRIFUGAL TIMER CPL. 03	1
52	47035054026	WATER PUMP GEAR 2003	1
53	47035058000	PIN 2X22	1
54	47035054000	WATER PUMP SHAFT 85 SX 2003	1
55	47035055000	WATER PUMP WHEEL 85 SX 2003	1
57	0603040801	COPPER GASKET DIN7603- A4X8X1	1
58	47037058000	LOCK SCREW CONTROL SHAFT 03	1
59*	47037057100	CONTROL SHAFT 85 SX 06	1
61	47035061000	SCREW M6X8	1
64	56509064100	SELF LOCKING NUT M6 10.9	1
65	47037065000	CONTROL LEVER 85 SX 2003	1
66	54637066000	OVERLOAD SPRING	1
67	47037067000	SPRING SLEEVE 85 SX 2003	1
68	47037068000	BEARING SLEEVE 85 SX 2003	1
75	0007050180	CYLINDER PIN DIN 7-5X18(M6)	1
85	47037085000	STOP SHEET 85 SX 2003	1
92	47037092000	GASKET RUBBER TOP 85 SX	1
93	47037093000	GASKET RUBBER BOTTOM 85 SX	1
95	47037095044	CONNECT. ROD CPL. 85 SX 03	1

064703700 / C064703700

\* NEW PART

X AS REQUIRED

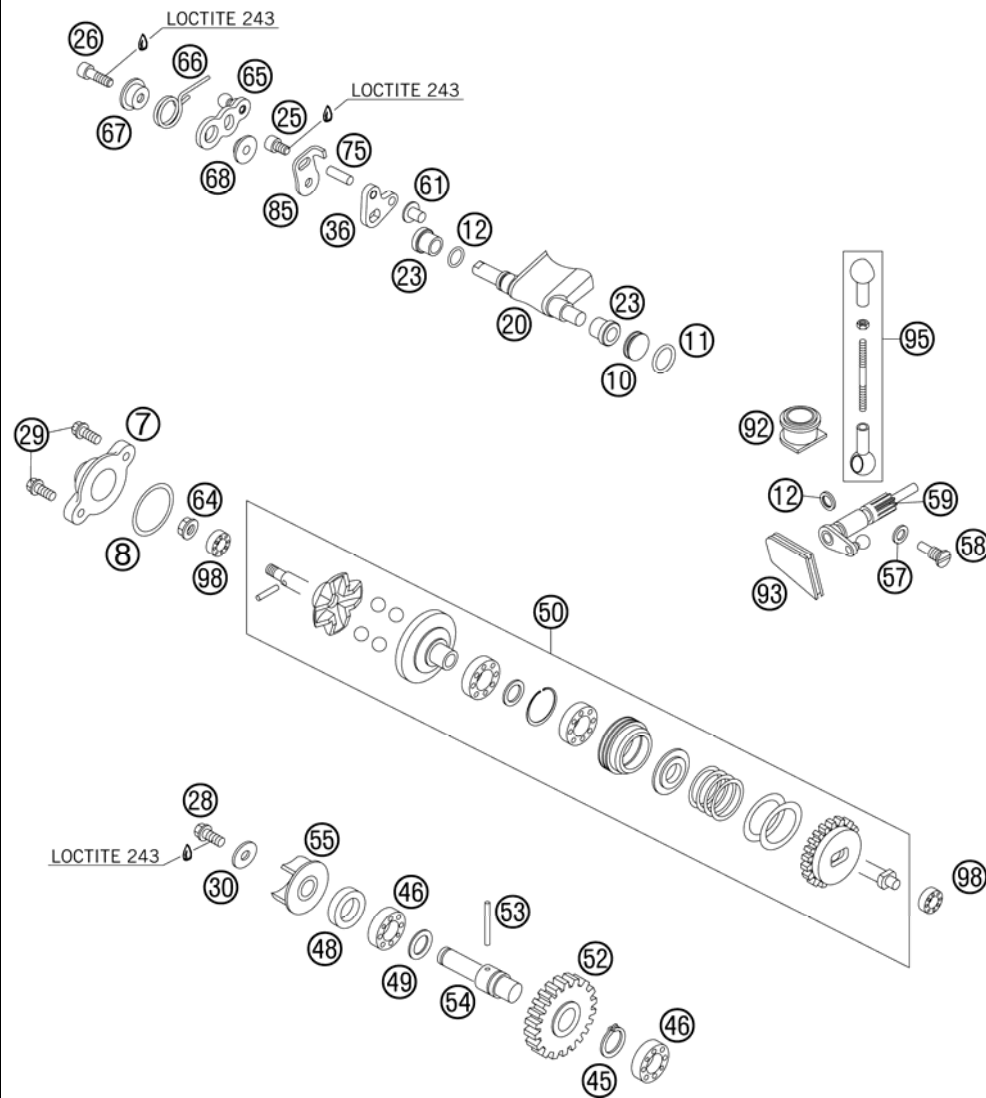

FIG	PART NUMBER	DESCRIPTION	QTY
98	54637098100	BALL BEARING 626LLBC3/5K	2

064703700 / C064703700

\* NEW PART

X AS REQUIRED

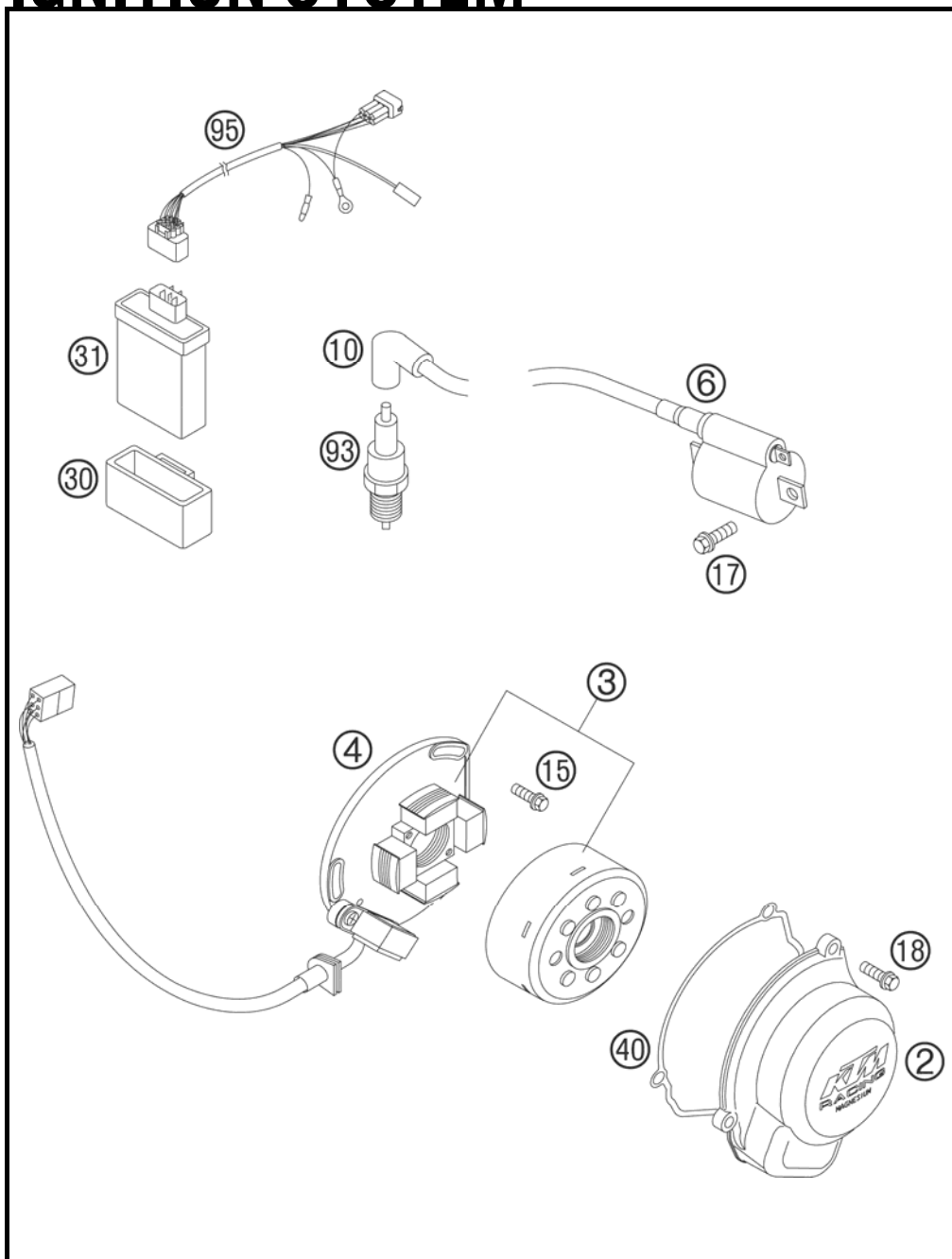
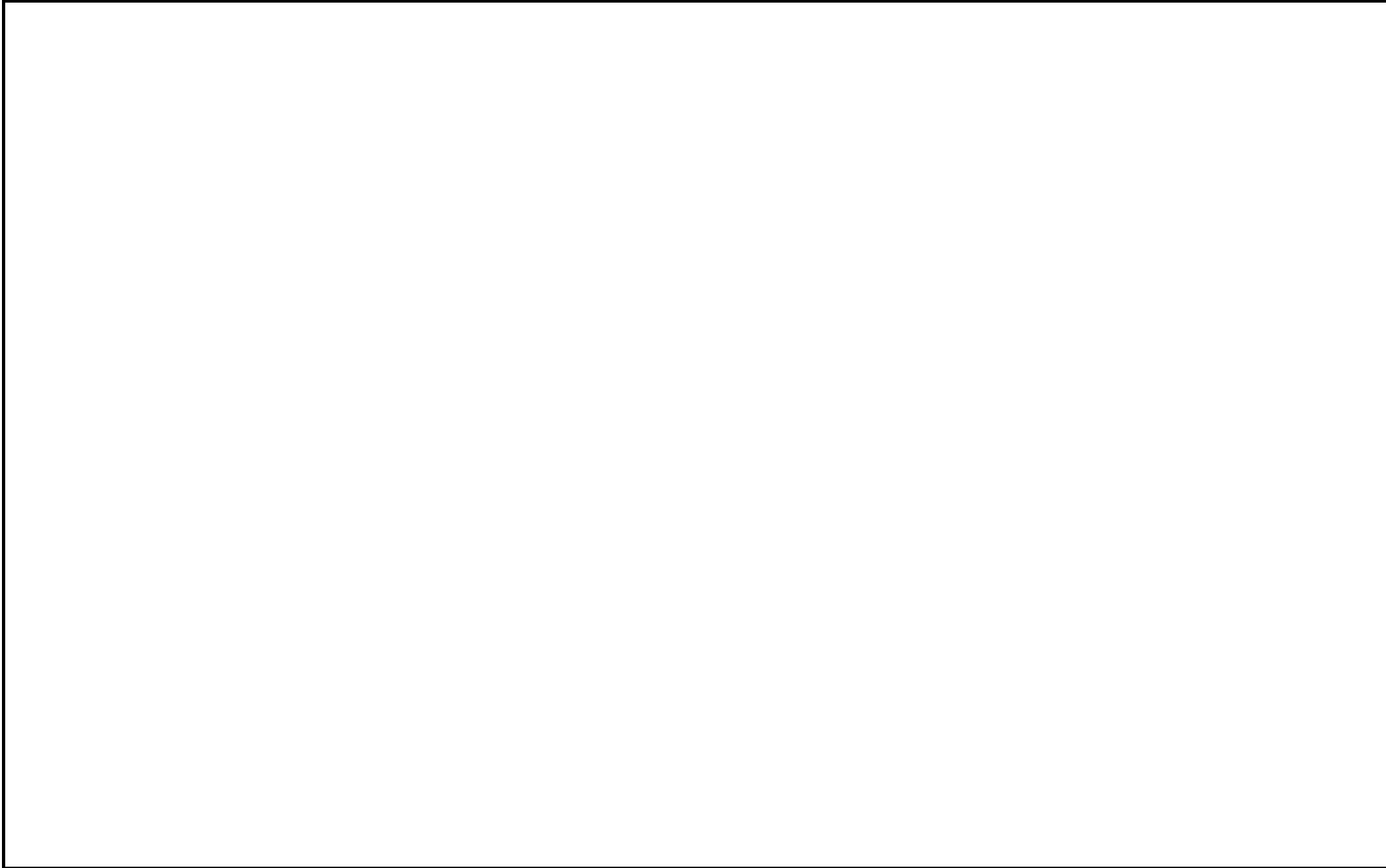

FIG	PART NUMBER	DESCRIPTION	QTY
2	47030002000	IGNITION COVER 85 SX 2003	1
3	46139002100	IGNITION CPL. 65 SX 2003	1
4	46139004000	STATOR 65/85 SX 2003	1
6	46139006100	IGNITION COIL CPL. 65 SX 2003	1
10	47039090000	SPARK PLUG CAP NGK REINFORC.04	1
15	0015050163	HH COLLAR SCREW M 5X16 WS=8	3
17	0015060163	HH COLLAR SCREW M 6X16 WS=8	2
18	0015060203	HH COLLAR SCREW M 6X20 WS=8	3
30	46139030000	RUBBER BR. DIGI.BOX 65SX 2003	1
31	47039031000	CDI UNIT 85 SX 2003	1
40	47030040000	IGNITION COVER GASKET 85 SX 03	1
93	47039093000	SPARK PLUG NGK BR10 ECMVX	1
95	46139095000	WIRING HARNESS 65 SX 2003	1

05470390 / C064703900

\* NEW PART

X AS REQUIRED









3CM080403EN

Art.Nr.: 3CM080403EN 6/2005



**KTM-Sportmotorcycle AG**  
A-5230 Mattighofen  
[www.ktm.at](http://www.ktm.at)